

INSTRUCTIONS
for installation and
operation
of electrical direct-heating
convector
PROTHERM

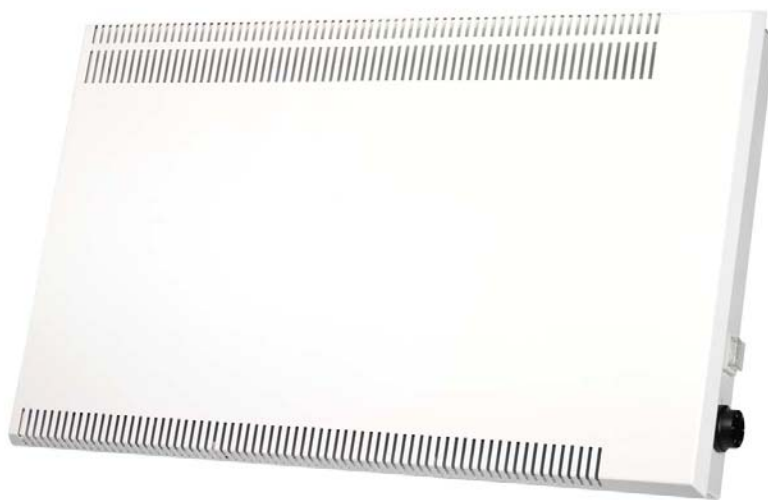

PROTHERM, s.r.o. *[Ltd]*
909 01 Skalica, Pplk Pljušť'a 45 , Slovak Republic
phone: +421 346966101
fax: +421 346966111

1 Function of an Electrical Convector

A convector is a heating device the function of which is based on conversion of electrical energy into heat and on the upward flow of warm air. It uses traditional principles of electrical heating and the chimney effect in an advanced combination.

Thus, an electrical conveyor forms something like a small chimney fitted with an electrical heating element in its bottom part. The element heats air which then flows upwards inside the convector and into the room it is heating. Cooler air drops down, the convector “takes it in”, reheats it and returns it back to into the room. Therefore, we can call the convector a “chimney radiator”, which can function without a fan, silently and efficiently. To achieve a pleasant temperature in a room, only minimum consumption of 30 W per cu.m is required.

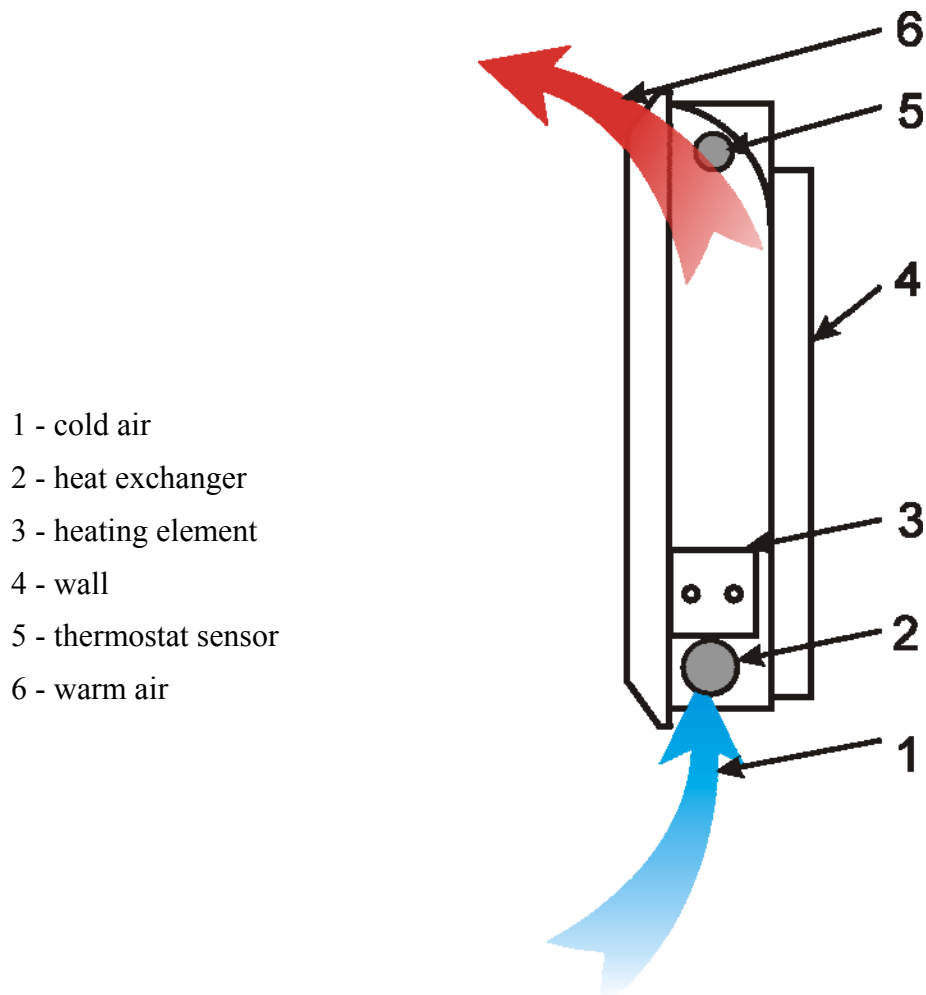

Fig. 1: Diagram of the chimney effect

The convector is a modern version of the tried-and-tested hot-air heating.

The convector is equipped with a thermostat for controlling the required room temperature between 5°C and 30°C. If more than one convectors are used connected to an independent power supply, the temperature can be regulated by a central room thermostat or a programmable regulator. The convector is fitted with a thermal fuse which cuts out the power supply to the convector in case of overheating.

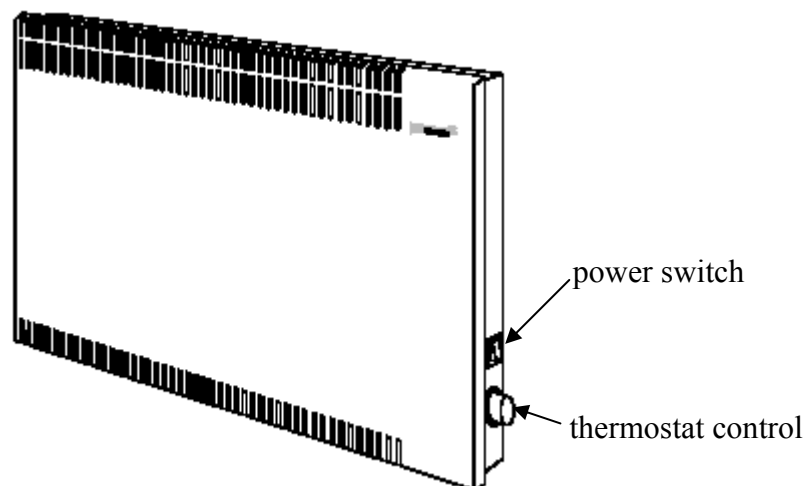

Fig. 2: Convector control panel

2 Technical Specifications

Output (W): 500, 1000, 1500, 2000

The convector output is specified on the product labelling and also on the heating element body for service purposes.

Regulation range: 5°C - 30°C

Nominal voltage: 230 V± 10 %, 50 Hz

Dimensions and weight

Type	dimensions (mm)	weight (kg)
0,5 kW	455 x 460 x 75	6,1
1 kW	455 x 460 x 75	6,1
1,5 kW	610 x 460 x 75	7,8
2 kW	765 x 460 x 75	9,6

3 Use

The electrical convector can be used:

- as an additional heating device to a current heating system (it can be easily plugged into an electrical socket)
- for comprehensive heating of flats, houses, offices, etc. at the attractive electricity rate BP.

4 Location and Installation

The convector is designed to be used in a normal environment AA5/AB5 as per ČSN 33 2000-3 and ČSN 33 2000-5-51 (i.e. ambient temperature + 5°C to + 40°C, humidity – depending on temperature – up to max. 85%). The wall on which the convector is mounted must be non-flammable (non-flammable materials classified in group A as per ČSN 73 0832). The convector must not be installed in rooms with a bath, bathrooms, wash rooms and showers, in zones 0, 1 and 2 as per ČSN 33 2000-7-701. It may not be installed also in zones 3 if there is a possible occurrence of water jets used for cleaning in municipal spas (municipal spas are baths and showers used in schools, factories, sports clubs, etc., including any other such facilities for public use).

If used in zone 3, extra local interconnection must be done as per ČSN 33 2000-7-701.

Convector must not be installed directly under the mains plug !

Wiring to a power mains and electrical installation must be performed only by an authorized person, qualified under Regulation No. 718/2002 Z.z.

Colour coding of conductors (to the fixed terminals in the preinstalled flush-mounted wall conduit box):

protective conductor – yellow-green

central conductor – light blue

phase conductor - brown

Electrical convector control is designed to be operated by persons without any electro-technical qualification. The person operating the convector may adjust only the controls specified in these Operating Instructions!

Assembly – suspension on a wall is depicted in Fig. 3.

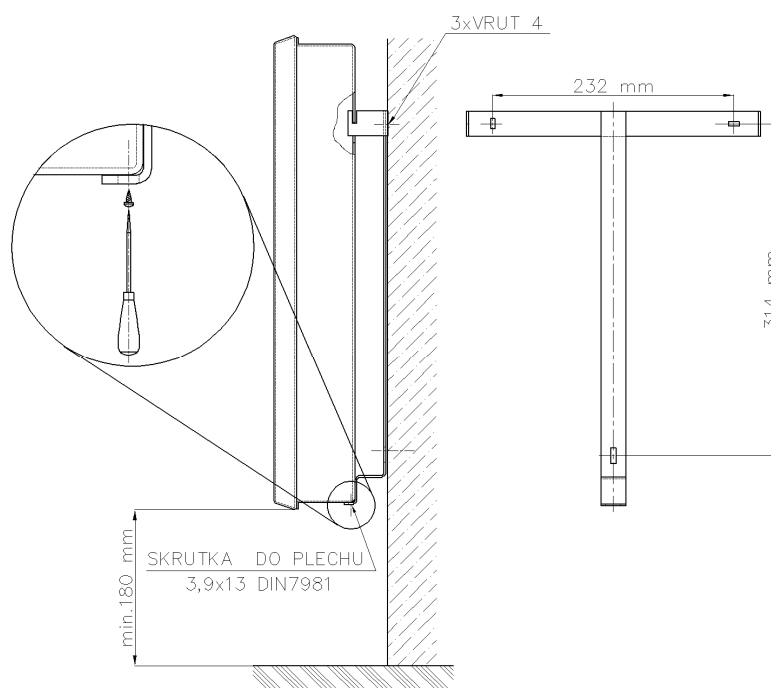

Fig. 3: Wall mounting

In order for the convector to function to your absolute satisfaction, the following conditions must be met:

- it must be mounted (we recommend suspended on a wall) so that the bottom edge is at least 15 cm above the floor,
- the convectors bottom and top openings must be free of obstacles to allow for unobstructed circulation of air,
- foreign objects (furniture) must not obstruct air circulation, and must be located at least 20 cm from the front, top and side walls of the convector.

5 Operation

Start the convector by switching on the power switch (see Fig.2). Set the thermostat controller to the maximum temperature position. Heat the room until the required temperature is achieved (check the room thermometer). Then turn the thermostat controller back towards a lower temperature until the convector switches off. Leave the thermostat in this position. The room temperature shall automatically be maintained at the selected value.

Caution:

During the first start up of the convector a slight odour might be perceived, which is caused by the burn-off of residues inside the convector. After longer time of not using convector (summer, holiday) after restarting up it could appear slight odour caused by the burn-off dust on the heating elements.

ATTENTION !

To prevent overheating, do not cover over convector !

6 Thermal Fuse

The convector is fitted with a fuse that cuts out the power supply to the heating element in case of convector overheating. This condition could arise only if you prevent the free circulation of air through the convector (unsuitable location of convector, covered convector air ducts, e.g. towel, etc.). After cooling the fuse is reset and the convector can be operated again.

7 Maintenance

The convector does not require any special maintenance. We recommend normal cleaning of the surface with a moist cloth and detergent. The convector must be switched off before cleaning. Dust can be removed from slits by vacuuming.

8 Failure and Repair

In case of convector failure, first check that the convector switch is turned on, and that the convector is plugged into a power socket. If it is, then check the thermostat setting and free circulation of air. If these measures do not help, seek advice from an authorized service centre. Service is provided by the dealer.

9 Delivery

The convector is supplied with a connected cable, 150 cm long, without terminal. The delivery also contains a special bracket for wall mounting.

10 Warranty

The supplier provides a warranty as is set out in the Warranty Certificate and the terms and conditions therein. Any defects subject to warranty must be reported to the supplier. The Warranty Certificate and proof of purchase must be submitted when making a warranty claim.

11 Safety

This product is approved under ŠS SKTC 101 .

The PROTHERM convector is a class 1 product, protection cover IP 31.

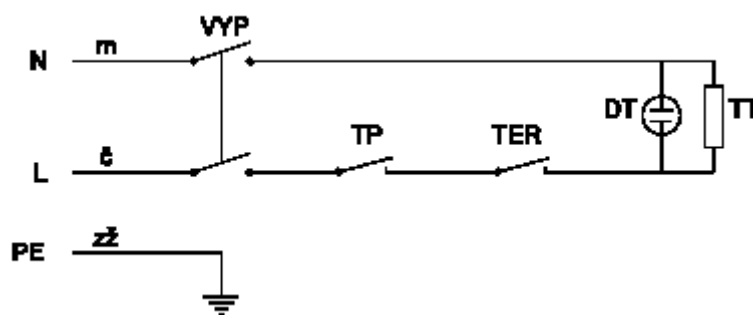

Fig. 4: Wiring diagram